

## Balancer Shafts Dynamic Adjustment

### WARNING

Before starting work, ensure the motorcycle is stabilised and adequately supported. This will help prevent it from falling and causing injury to the operator or damage to the motorcycle.

### WARNING

If the engine has recently been running, the engine oil will be hot to the touch. Contact with the hot oils may cause damage to exposed skin. To avoid skin damage, do not touch hot oil.

### WARNING

If the engine has recently been running, the exhaust components may be hot to the touch. Contact with the hot components may cause damage to exposed skin. To avoid skin damage, always allow the hot parts to cool before working on the exhaust system.

### WARNING

The cooling fan is switched on and off by the Engine Control Module in response to a signal received from the coolant temperature sensor. To prevent injury, never place loose clothing, fingers or hands near the cooling fan, until the engine is stopped. Loose clothing, fingers or the hands could become trapped during cooling fan operation and cause crushing injury to the fingers, hands or other parts of the anatomy.

### WARNING

Never start the engine or run the engine in a confined area. Exhaust fumes are poisonous and can cause loss of consciousness and death within a short period of time. Always operate your motorcycle in the open-air or in an area with adequate ventilation.

#### Note

- Before dynamically adjusting the front and rear balancer shafts the engine coolant fan must have cycled once and the coolant temperature must be at least 103°C.

## Front Balancer Shaft Dynamic Adjustment

1. Start the motorcycles engine and allow to run to operating temperature.

### CAUTION

The dead shaft is an eccentric shaft which runs inside the balancer shaft. When rotated the dead shaft therefore closes or opens the gap between the teeth of the balancer gear and the teeth of the crankshaft gear.

If the gap between the balancer gear and crankshaft gear is too small a whine is audible due to the increased load on the gear teeth and bearings.

If the gap between the balancer gear and crankshaft gear is too large a rattle is audible due to the increased gap between the gear teeth.

The balancer shafts must always be adjusted in the same operation.

Adjusting the front or rear balancer shafts individually may cause the engine to whine or rattle.

Unsatisfactory adjustment of the balancer shafts may cause severe engine damage.

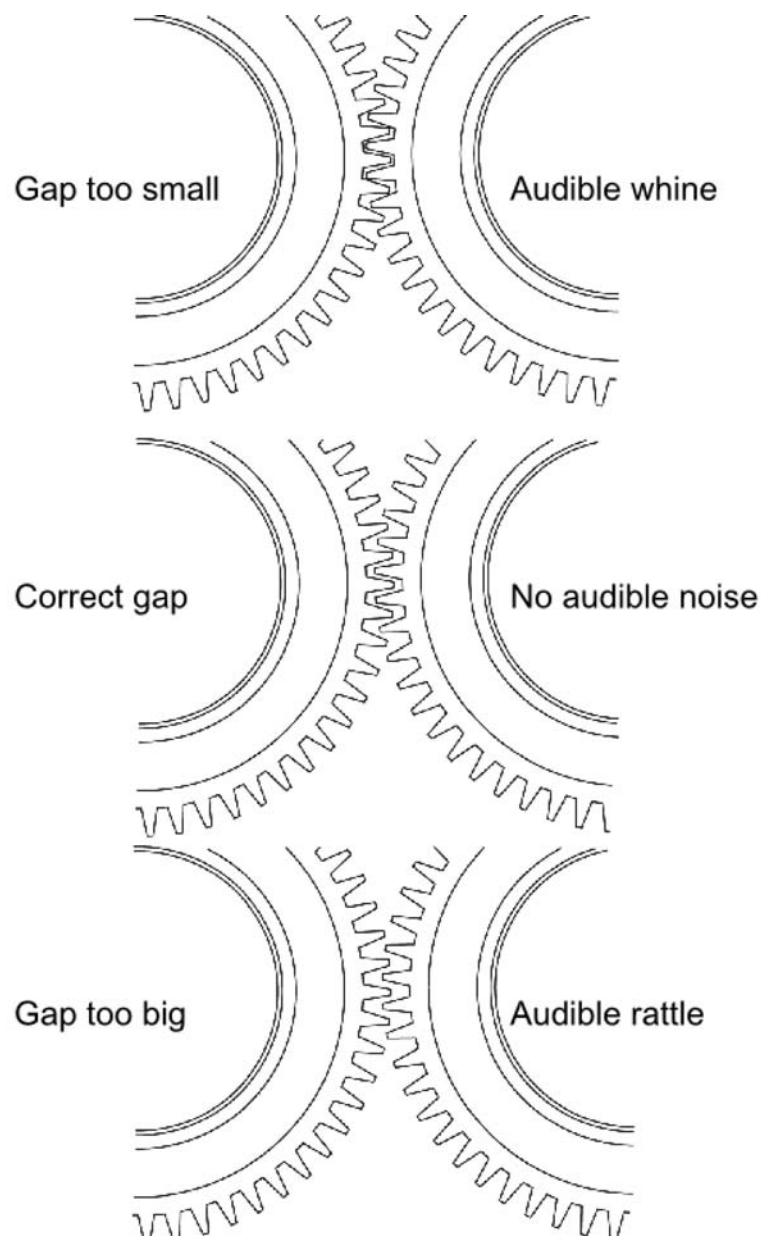

2. Stop the engine.
3. Remove the embellisher from the alternator cover and discard the fixings.
4. Remove the dead shaft clamp blanking plug and discard the washer.

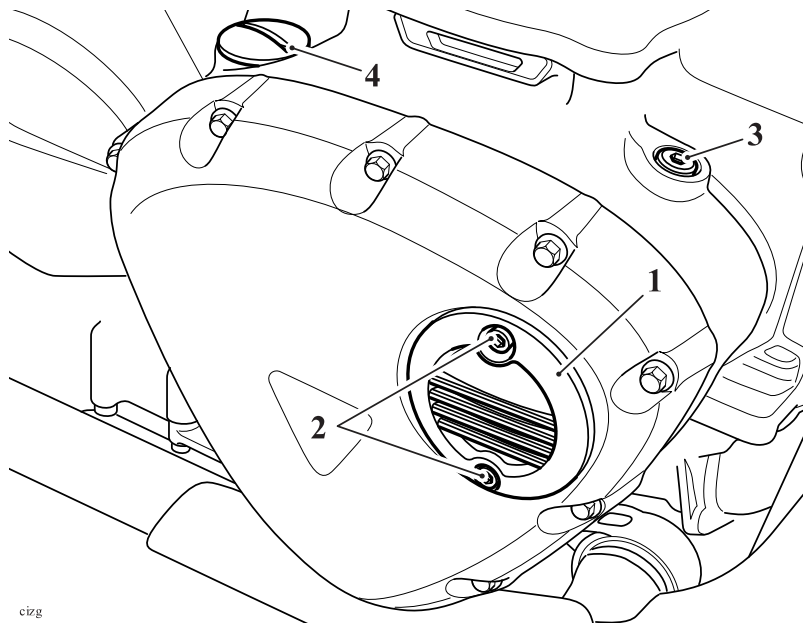

cizg

1. Embellisher
2. Fixings
3. Dead shaft clamp blanking plug
4. Oil filler cap

5. Loosen the dead shaft clamp locking screw a maximum of two complete turns to allow smooth rotation of the balancer dead shaft in the clamp.

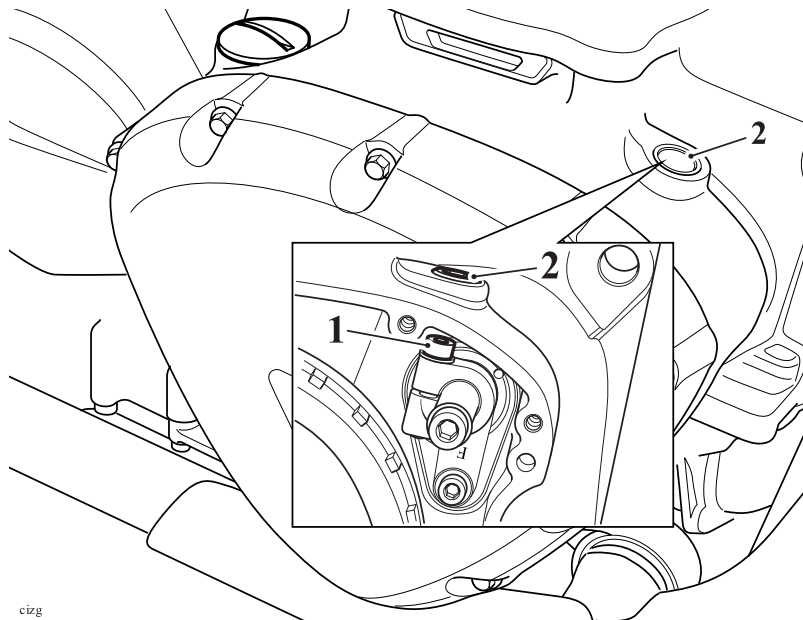

cizg

1. Dead shaft clamp locking screw
2. Blanking plug orifice

 **CAUTION**

When adjusting the balancer shafts do not allow the gears to whine or rattle for a prolonged period.

Allowing the gears to mesh incorrectly for extended periods may cause damage to the gears and or bearings.

6. Start the engine and allow to idle.

7. Gently rotate the dead shaft clockwise until a whining noise can just be heard.

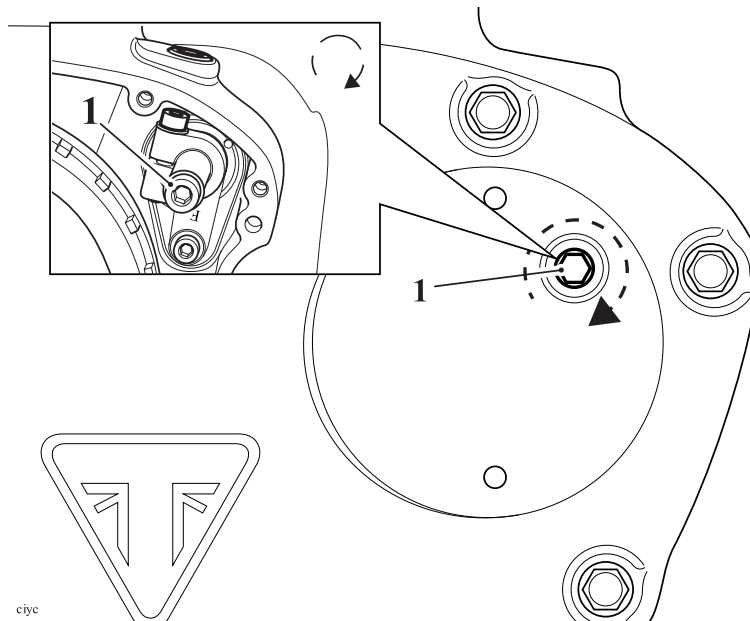

### 1. Dead shaft

8. Rotate the dead shaft anti-clockwise until the whining noise can no longer be heard.

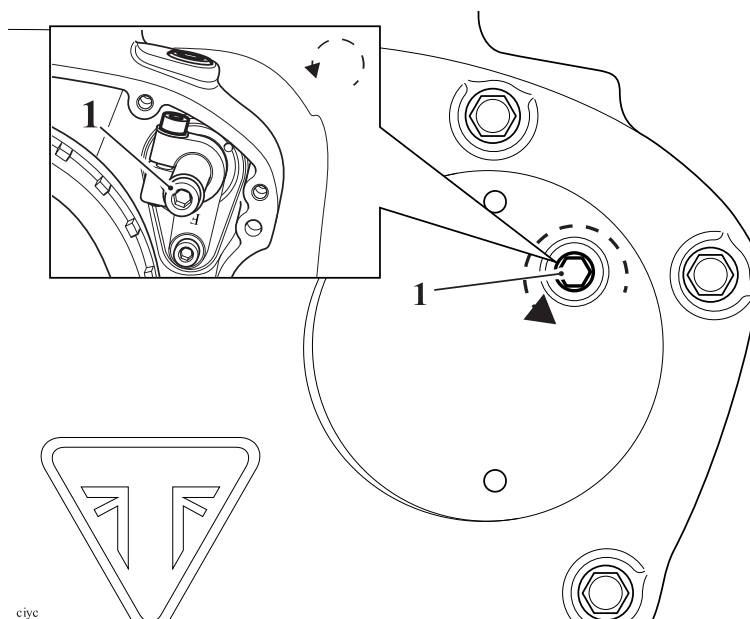

### 1. Dead shaft

9. Tighten the dead shaft clamp locking screw to **10 Nm**.
10. Stop the engine.

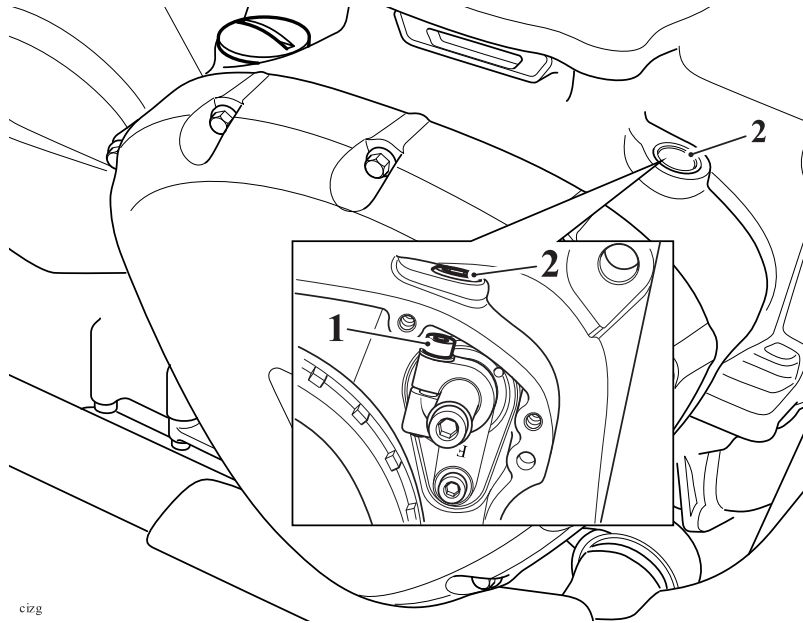

1. Dead shaft clamp locking screw
2. Blanking plug orifice

11. Wipe away any spilt oil from the crankcase.
12. Fit a new washer and tighten the dead shaft clamp blanking plug to **23 Nm**.
13. Refit the embellisher cover to the alternator cover, tighten the new screws to **4 Nm**.

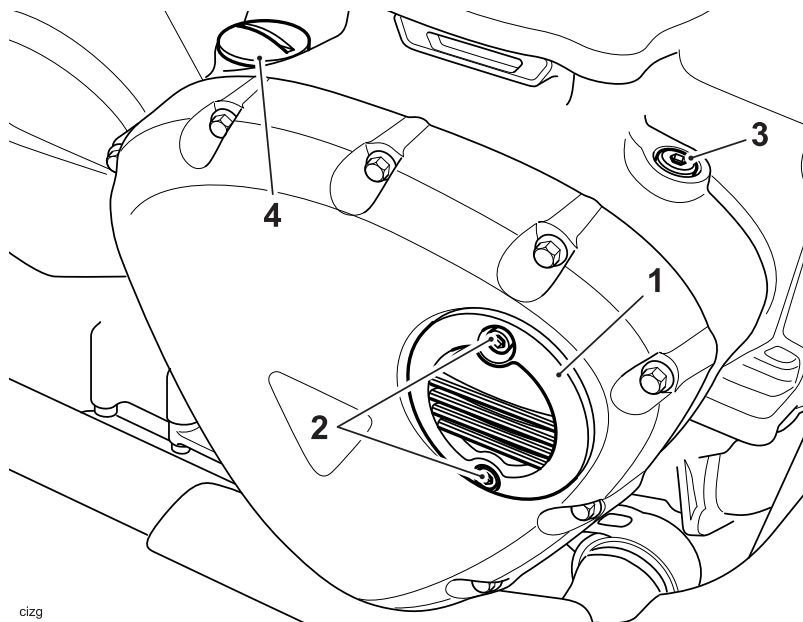

1. Oil filler cap
2. Embellisher
3. Dead shaft clamp blanking plug

#### 4. Oil filler cap

### Rear Balancer shaft Dynamic Adjustment

1. Remove the clutch cover plug.

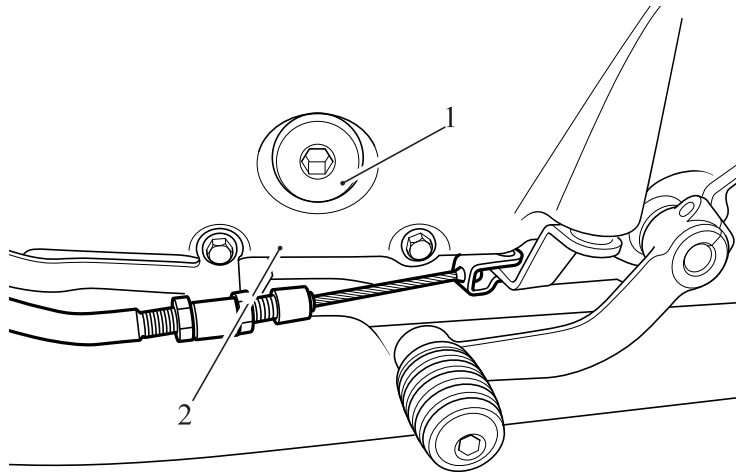

cwp\_1

1. Clutch cover plug
2. Clutch cover

2. Remove the oil filler cap and discard the o-ring.

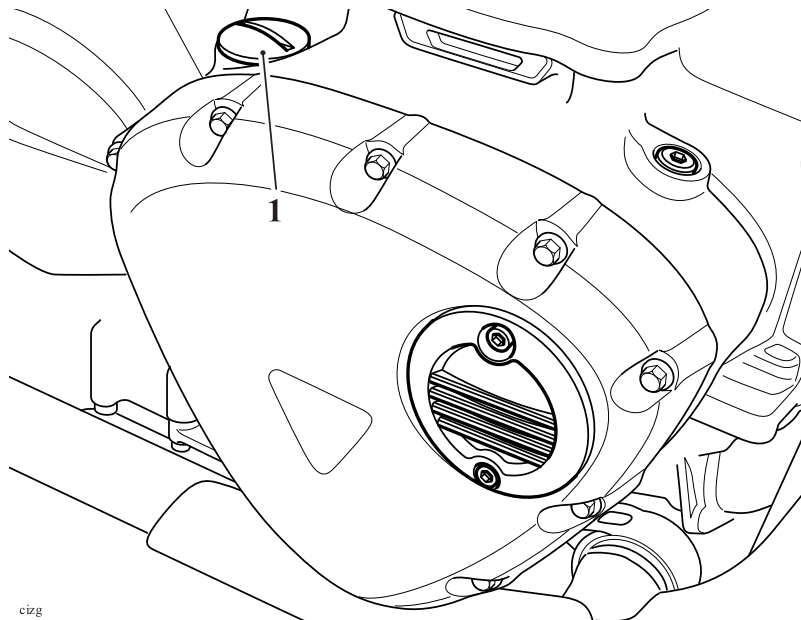

cizg

1. Oil filler cap

3. Using T3880652 - Dead Shaft Key Tool, loosen the dead shaft clamp locking screw two full turns.

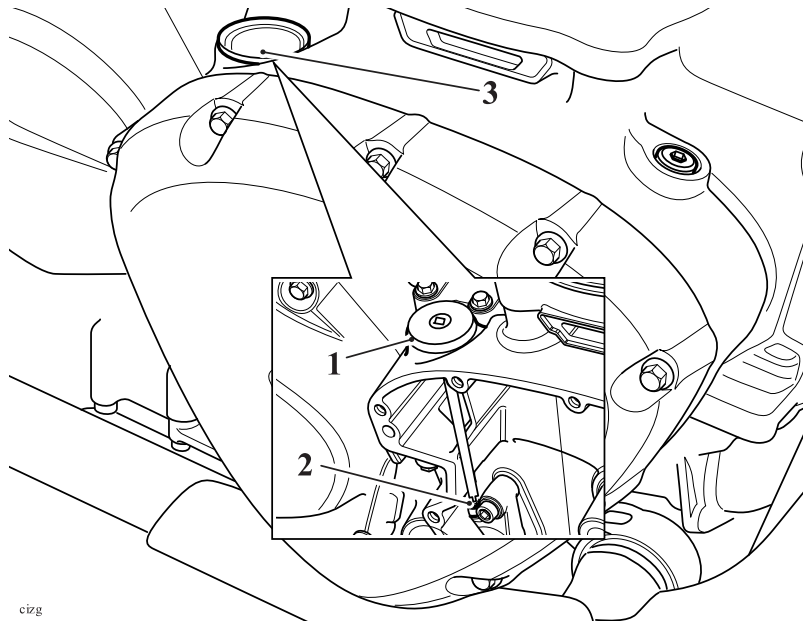

1. T3880652 - Dead Shaft Key Tool
2. Dead shaft clamp locking screw
3. Oil filter orifice

4. Rotate the rear dead shaft clockwise until a whining noise can be heard.

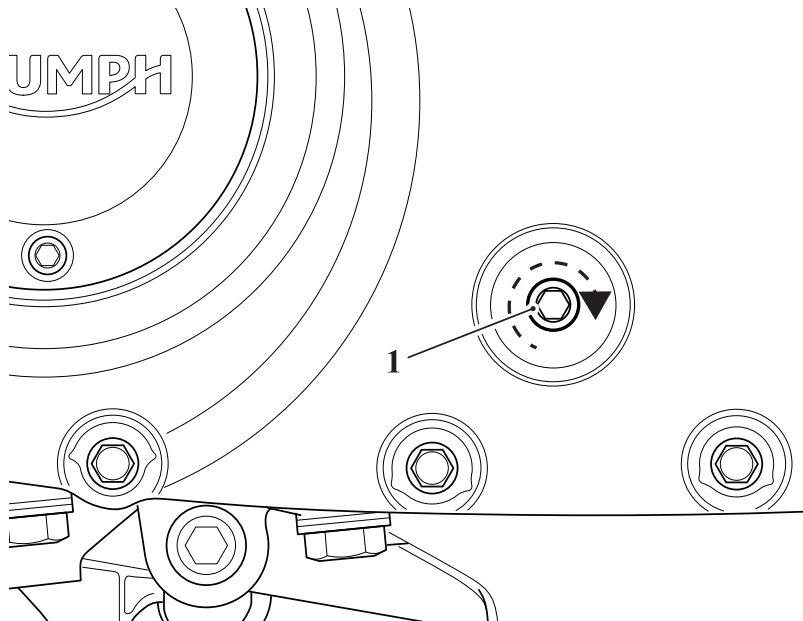

1. Dead shaft

5. Rotate the dead shaft anti-clockwise until the whining noise can no longer be heard.

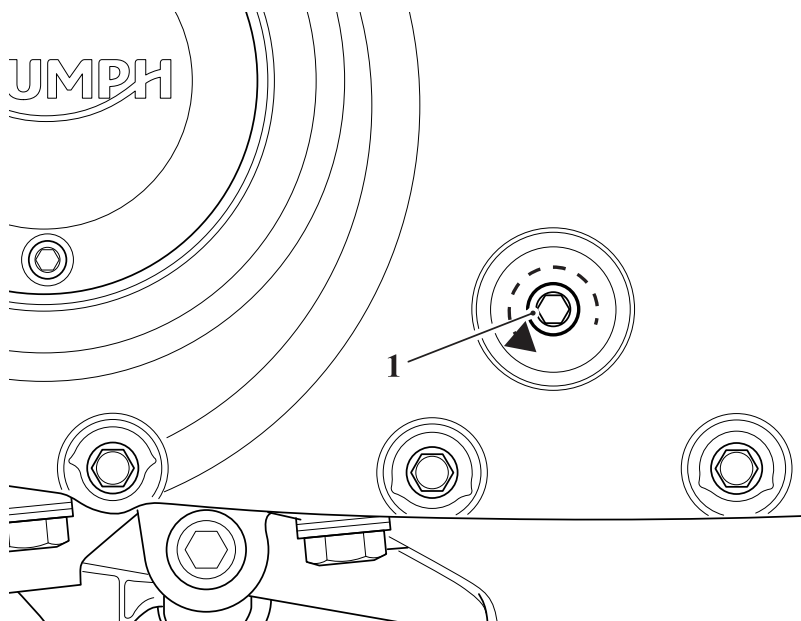

### 1. Dead shaft

6. Using T3880652 - Dead Shaft Key Tool tighten the dead shaft clamp locking screw to **10 Nm**.
7. Wipe away any spilt oil from the upper crankcase.
8. Using a new O-ring refit the oil filler cap and tighten to **3 Nm**.

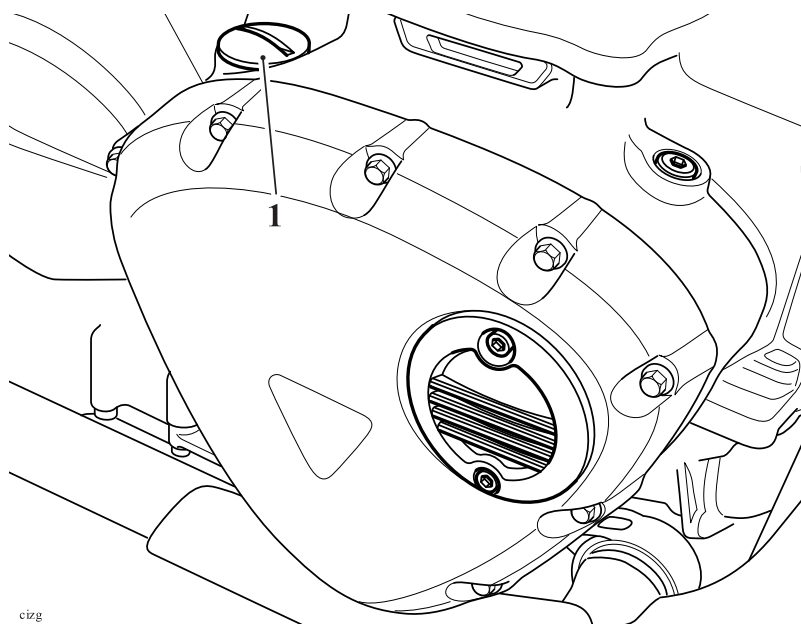

### 1. Oil filler cap

9. Refit the clutch cover plug and tighten to **3 Nm**.

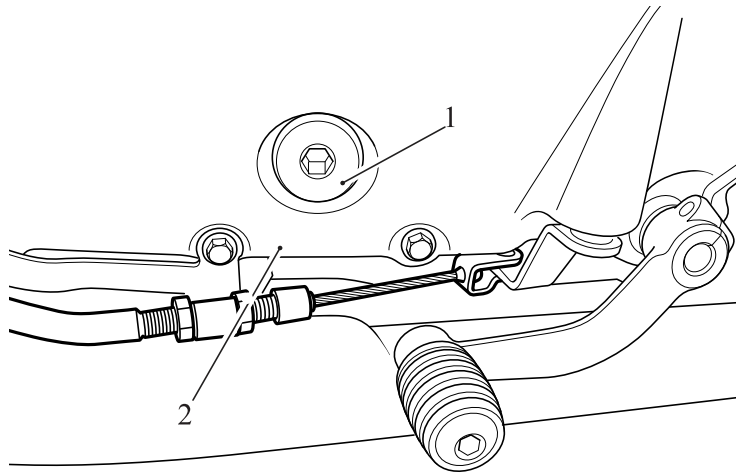

clmp\_1

1. Clutch cover plug
2. Clutch cover

10. Inspect the engine oil level (see [Engine Oil - Level Inspection](#)).